

# T0-3

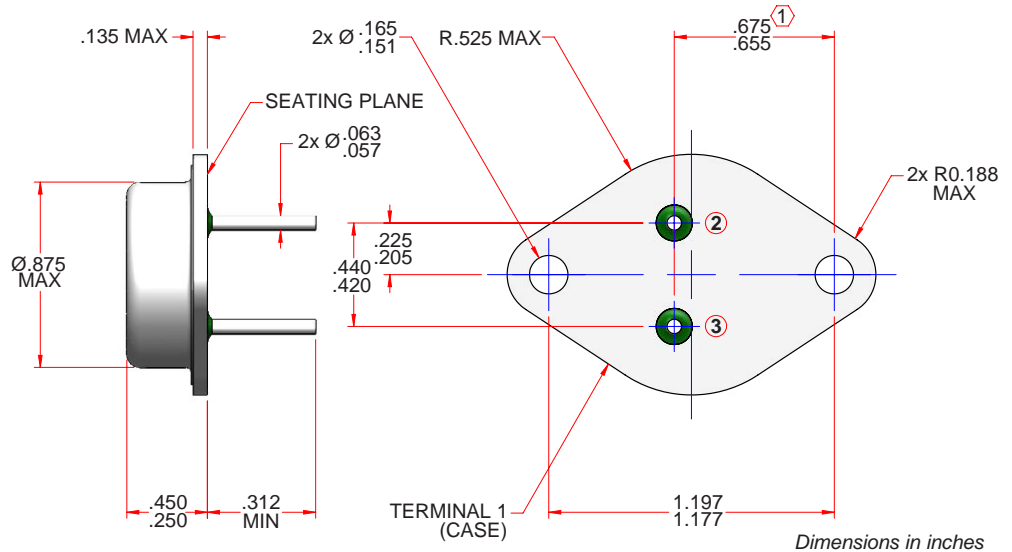

- Hermetically sealed package
- Ceramic seals for improved hermeticity available
- Weight: 14.6 g [typ]

*\*dime used for size reference*



#### NOTES:

- ① This dimension shall be measured at points .050" - .055" below the seating plane. When gage is not used, measurement will be made at seating plane. This outline does not meet the minimum criteria established by JS-10 for registration.